

KIT PART NUMBER 7644012

INSTRUCTIONS FOR INSTALLING A 115 V PAN AND HEATER ASSEMBLY

CHECK THE PARTS RECEIVED IN THE KIT WITH THE PARTS LIST IN THESE INSTRUCTIONS. IF ANY PARTS ARE MISSING, CONTACT THE NATIONAL VENDORS PARTS DEPARTMENT IMMEDIATELY.

Read these instructions carefully before installing the kit.
Keep these instructions for part numbers and for future reference.

This kit contains the following :

PART NUMBER	DESCRIPTION	QUANTITY
7644013	PAN AND HEATER ASSEMBLY - 115 V	1
2204513	WIRE TIE	1
3104053	INSULATION TAPE	-

NOTE

Turn the main power switch OFF before starting installation.

1. Remove the front panel from the refrigeration module.

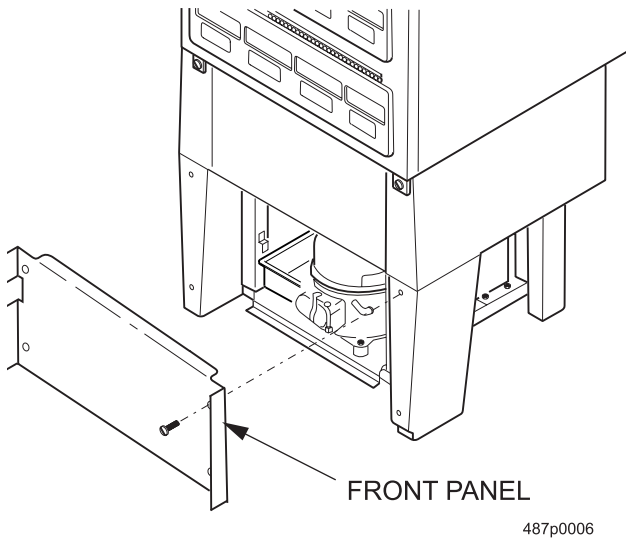

2. Remove the condensate pan (4644029) by first removing the condensate pan bracket (4534063). Lift the discharge tube coil high enough to allow removal of the condensate pan. Take care not to kink or flatten the discharge tubing. Remove the condensate pan. Discard the discharge tube spacers.

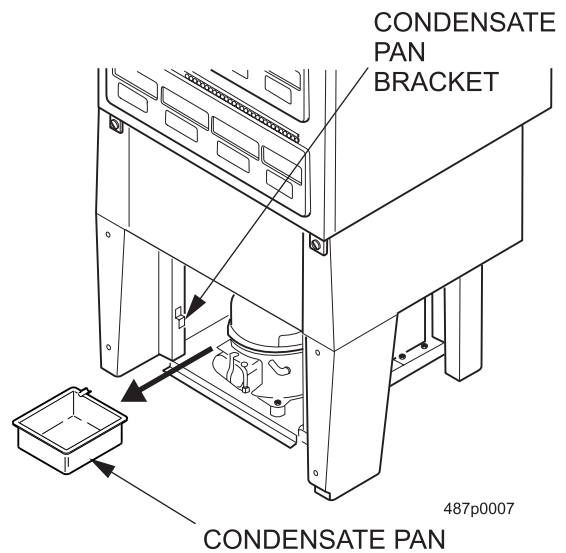

- Install the new pan and heater assembly (7644013) by first placing one 2" strip of insulation (cork) tape (3104053) on the bottom rear of the pan. Place two 1" strips of insulation tape on the bottom front of the pan. Slide the pan and heater assembly into the refrigeration module, making sure not to damage refrigeration tubing. Push down slightly on the pan and heater assembly to ensure the insulation sticks to the refrigeration module chassis.

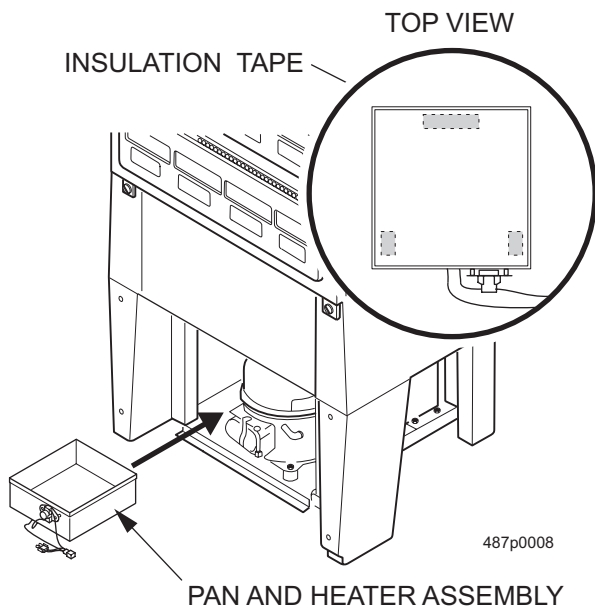

- Lower the refrigeration discharge tubing back to its original location. Take care not to kink or flatten tubes.

- Disconnect the two terminals of the lighting harness. Connect the "Y" end of the pan and heater assembly harness (7849011) to the lighting harness as shown.

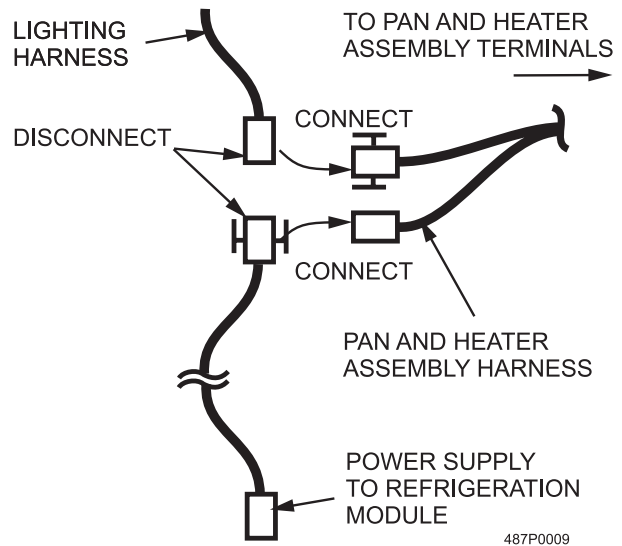

- Connect the other end of the pan and heater assembly harness to the pan and heater assembly. Secure the harness with a wire tie (2204513).
- Reinstall the condensate pan bracket (4534063) removed earlier.
- Reinstall the front panel of the refrigeration module removed in an earlier step.
- Turn main power ON.